

Datasheet GRENTON SMART PANEL CUSTOM LEATHER

SPS-804-T-0x

FOUR CAPACITIVE BUTTONS TOUCH PANEL WITH THE OLED DISPLAY AND HAND GESTURE CONTROL.

Replacing traditional wall switches, Grenton Smart Panel allows to control not only the light, but also any device in a smart home. The Panel provides information from sensors, system parameters or its functional data. The versatile and intuitive control interface makes it easy and quick to control an individual device or the whole home. There are 16 virtual buttons at our disposal, spread over 4 pages. The pages can also control the thermostats defined in the system. The Distributed-Logic mode enables operation in the case of no communication with the CLU. More advanced users appreciate the "freedraw" mode that allows to generate any interface.

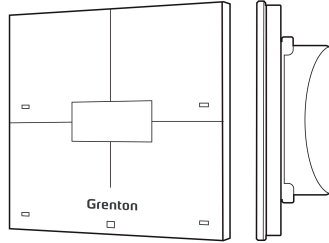

1. Parameters - PANEL_BUTTON

Properties:	
Value	Returns button input state as 0 or 1
Mode	Returns the selected mode of button action (0 - monostable, 1 - bistable, 2 - locked)
HoldDelay	Time in milliseconds after which, when pressing and holding a button, the OnHold event occurs
HoldInterval	Cyclical interval in milliseconds after which, when pressing and holding a button, the OnHold event occurs
Label	The text that describes the button
IconA	The file name of the icon assigned to the button in monostable and bistable mode in the OFF position. The name preceded by "~" displays the graphic in negative. IconA has priority on the Label property
IconB	The file name of the icon assigned to the button in bistable mode in the ON position. The name preceded by "~" displays the graphic in negative
Methods:	
SetMode	Sets mode of button action (0 - monostable, 1 - bistable, 2 - locked)
SetHoldDelay	Sets HoldDelay value
SetHoldInterval	Sets HoldInterval value
SetLabel	Sets Label value
SetIconA	Sets IconA value
SetIconB	Sets IconB value
ShowOK	Forces the green diode on the button to flash for 2 seconds (frequency 500 ms). The red diode on the button is off
ShowError	Forces the red diode on the button to flash for 2 seconds (frequency 500 ms). The green diode on the button is off
LedSwitchOn	Activates the green diode on the button
RedLedSwitchOn	Activates the red diode on the button
LedSwitchOff	Deactivates all the diodes on the button
Events:	
OnValueChanged	Event occurs when a change in the input state takes place (regardless of the value)
OnSwitchOn	Event occurs when the high state is set at input
OnSwitchOff	Event occurs when the low state is set at input
OnShortPress	Event occurs after pressing the button for 500 ms - 2000 ms
OnLongPress	Event occurs after pressing the button for longer than 2000 ms
OnHold	Event occurs for the first time after HoldDelay time passes and then cyclically every HoldInterval value
OnClick	Event occurs after pressing the button for less than 500 ms

2. Parameters - PANEL

Properties:	
GestureIconUp	The BMP file name of the icon for gesture Up (without extension)
GestureIconDown	The BMP file name of the icon for gesture Down (without extension)
GestureIconLeft	The BMP file name of the icon for gesture Left (without extension)
GestureIconRight	The BMP file name of the icon for gesture Right (without extension)
ProximitySens	Sensitivity of the proximity sensor (less value-more sensitivity)
ProximityTimeout	The time after which the display will be blanked
ProximityValue	Proximity sensor value (dimensionless value)
BuzzerValue	Sound indication control (0 - Off, 1 - On)
GestureMode	Selection of gestures orientation (0 - Off, 1 - Vertical, 2 - Horizontal, 3 - Vert+Horiz)
GestureSens	Selection of gestures sensitivity (1 - Low, 2 - Mid, 3 - High)
PageNr	Number of the current page displayed
PageDisplayMode	Notification before changing the page (0 - ShowImmediately, 1 - ShowIconOrName, 2 - ShowGesture)
ButtonsLEDMode	Buttons location using very low LED light (0 - LocationLedOFF, 1 - LocationLedON, 2 - LocationLedONforActive)
PageControlMode	The source that switches the pages (0 - Command, 1 - Gesture/Command)
GestureDisplayMode	Displays information about the currently performed gesture (0 - Off, 1 - On)
Methods:	
SwitchOnDisplay	Wakes the display from sleep mode
ShowButtons	Changes display mode into 'buttons'. Clears the display and shows the icons (or text) for every button
ClearScreen	Clears the display in 'freedraw' mode
PrintText	Displays the text in 'freedraw' mode using parameters: (x, y, txt, font size)
PrintFloat	Displays the float number in 'freedraw' mode using parameters: (x, y, number, precision, font size)
DrawLine	Draws the line in 'freedraw' mode using the parameters: (x, y, xe, ye, color)
DrawBox	Draws the filled with color rectangle in 'freedraw' mode using the parameters: (x, y, w, h, color)
DrawPoint	Draws the point in 'freedraw' mode using the parameters: (x, y, color)
DrawIcon	Draws the icon (bmp) in 'freedraw' mode using the parameters: (x, y, Filename)
DisplayContent	Displays the memory graphic buffer content. Changes display mode to "freedraw"
SetGestureIconUp	Sets the icon for gesture Up
SetGestureIconDown	Sets the icon for gesture Down
SetGestureIconLeft	Sets the icon for gesture Left
SetGestureIconRight	Sets the icon for gesture Right
SetProximitySens	Sets the ProximitySens value
SetProximityTimeout	Sets the ProximityTimeout value (in seconds)
SetBuzzerValue	Sets the BuzzerValue (0 - Off, 1 - On)
SetGestureMode	Selection of gestures orientation (0 - Off, 1 - Vertical, 2 - Horizontal, 3 - Vert+Horiz)
SetGestureSens	Selection of gestures' sensitivity (1 - Low, 2 - Mid, 3 - High)
SetBeep	Generates sound according to frequency [Hz], duration [ms] and volume (freq, dur, vol, res)
SetPageNr	Sets the number of the page to be displayed
SetPageDisplayMode	Sets the mode of display notification before changing the page (0 - ShowImmediately, 1 - ShowIconOrName, 2 - ShowGesture)
SetButtonsLEDMode	Sets the buttons' location mode using very low LED light (0 - LocationLedOFF, 1 - LocationLedON, 2 - LocationLedONforActive)
SetPageControlMode	Sets the source that switches the pages (0 - Command, 1 - Gesture/Command)
SetGestureDisplayMode	Sets the mode of display information about the currently performed gesture (0 - Off, 1 - On)
SetNextPage	Forces the next page to be displayed
SetPrevPage	Forces the previous page to be displayed
Draw	Triggers the OnDraw event when OLED is active
Events:	
OnGestureUp	Event occurs after gesture Up
OnGestureDown	Event occurs after gesture Down
OnGestureLeft	Event occurs after gesture Left
OnGestureRight	Event occurs after gesture Right
OnProximityDetect	Event occurs after detection an object in front of the Smart Panel
OnPageChange	Event occurs after page change
OnDisplayOn	Event occurs after display on
OnDisplayOff	Event occurs after display off

3. Parameters - PANEL_PAGE

Properties:	
PageType	The type of page displayed on the Smart Panel (0 - Inactive, 1 - Buttons, 2 - Thermostats, 3 - FreeDraw)
PageName	Page Name/Icon Name of page displayed on the Smart Panel
Object_X_Id	Sets the ID of the thermostat object or virtual button number depending on page type e.g.: For Thermostats page type: - on the local CLU: THE1325 - on the remote CLU: CLU22000001->THE4321 For Buttons/FreeDraw page type, enter the number of the virtual button (1-16). X - object no. [1..4]
Object_X_Name	Name of the thermostat displayed on the Smart Panel page (no name - thermostat inactive). In the case of Buttons or FreeDraw page type, the Object_X_Name property should be empty. X - object no. [1..4]
Object_X_CustomIcon	Name of the custom icon name of the thermostat managed by the Smart Panel pages. An empty property changes the custom icon to the default 'chmode.bmp' or displays the label 'mode' when missing the default icon's BMP file. For page type set to Buttons or FreeDraw, the property remains empty. Setting an icon wider than 64 pixels and/or higher than 32 pixels may overwrite a part or all of the thermostat's UI
DistributedLogicGroup_X	Distributed Logic group - broadcast group for distributed logic. The property active only for Buttons page type. X - object no. [1..4]
Methods:	
SetPageType	Sets the type of page displayed on the Smart Panel
SetPageName	Sets the page name/icon name of page displayed on the Smart Panel
SetObject_X_Id	Sets the ID of the thermostat object or the button number due to page type. X - object no. [1..4]
SetObject_X_Name	Sets the Name of the thermostat displayed on the Smart Panel page (no name - thermostat inactive). In the case of Buttons or FreeDraw page type, the Object_X_Name parameter should be empty. X - object no. [1..4]
SetObject_X_CustomIcon	Sets the custom icon name of the thermostat managed by the Smart Panel pages. X - object no. [1..4]
Events:	
OnPageOpen	Event occurs after new page is shown
OnPageClose	Event occurs after actual page is closed
OnDraw	Event occurs after FreeDraw page wants to be redrawn
OnThermXModeButtonClick	Event occurs after top-left 'mode' button click in the thermostat no. X

4. Parameters - PANELSENSTEMP (temperature sensor)

Properties:	
Threshold	Hysteresis (accuracy 0.1°C) specifying the sensitivity when the following events are generated: OnValueChanged, OnValueLower, OnValueRise
Sensitivity	Period (in ms), for which the sampled values are averaged
Value	Temperature sensor value from 0.0 to 45.0°C
Calibration	Temperature calibration factor within -10°C to +10°C
MinValue	Minimum value of the Value property after exceeding which the OnOutOfRange event is generated
MaxValue	Maximum value of the Value property after exceeding which the OnOutOfRange event is generated
Events:	
OnValueChanged	Event resulting from changing input state
OnValueRise	Event resulting from exceeding the upper threshold of hysteresis
OnValueLower	Event resulting from exceeding the lower threshold of hysteresis
OnOutOfRange	Event resulting from exceeding the range (MinValue - MaxValue)

5. Parameters - PANELSENSLIGHT (light sensor)

Properties:	
Threshold	Hysteresis (accuracy 0.1%) specifying the sensitivity when the following events are generated: OnValueChanged, OnValueLower, OnValueRise
Sensitivity	Period (in ms), for which the sampled values are averaged
Value	Light sensor value from 0 to 100%
MinValue	Minimum value of the Value property after exceeding which the OnOutOfRange event is generated
MaxValue	Maximum value of the Value property after exceeding which the OnOutOfRange event is generated
Events:	
OnValueChanged	Event resulting from changing input state
OnValueRise	Event resulting from exceeding the upper threshold of hysteresis
OnValueLower	Event resulting from exceeding the lower threshold of hysteresis
OnOutOfRange	Event resulting from exceeding the range (MinValue - MaxValue)

6. Gestures



7. Preinstalled pictograms (different size)

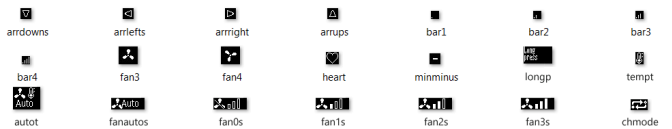

8. Preinstalled pictograms (128x64)



9. Preinstalled pictograms (64x32)

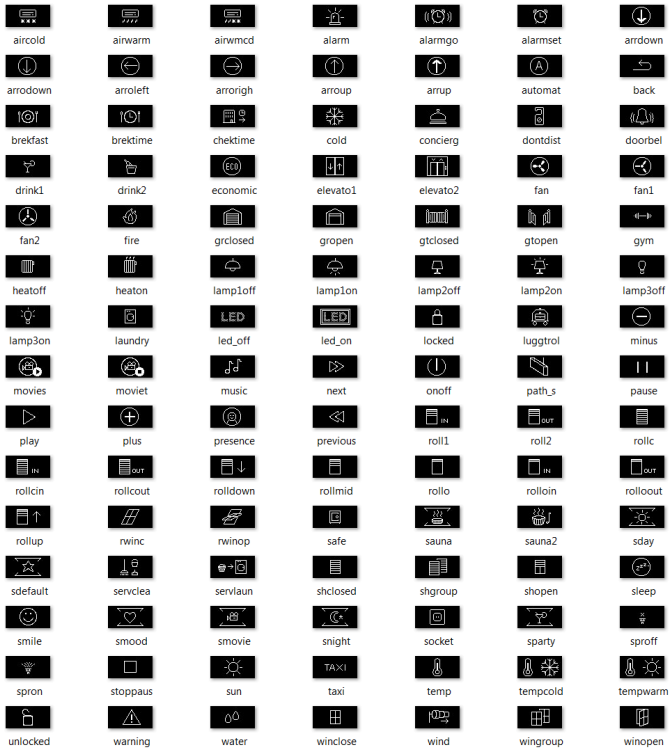

10. Technical Data

Device power supply	5 - 24 V _{dc}
Maximal power consumption	0.4 W
Maximal device current	17 mA (for 24 V)
Maximal wire cross section	1.5 mm ²
Weight	120 g
Dimensions (H/W/D)	surface part: 80/80/10 mm, concealed part: Ø 50 mm / h:22 mm
Operating temperature range	10 to 35°C
Humidity range	40 to 70 %

11. MicroSD card installation

The card should be installed with the power supply turned off.

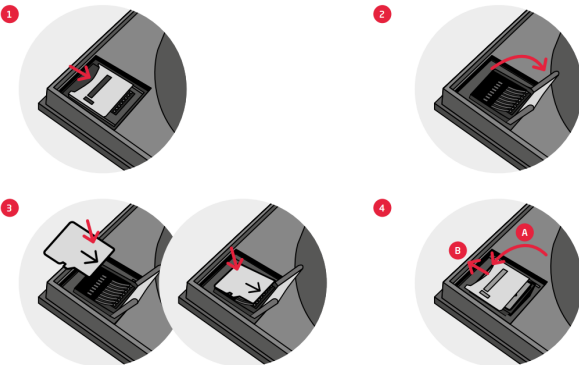

12. Wiring diagram

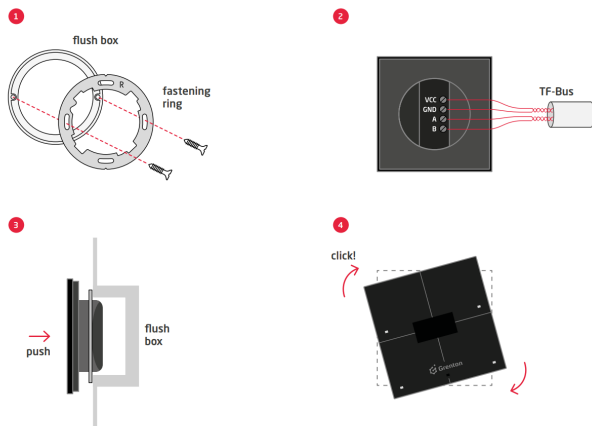

Vcc	power supply signal
GND	power supply ground signal
A	TF-bus A signal
B	TF-bus B signal

13. Support for DistributedLogic mode

DistributedLogic mode enables functioning of the Grenton TF-Bus modules without the CLU control unit. The DistributedLogicGroup_X parameter has been added to each of the 4 objects assigned to the page object (PANEL_PAGE). This parameter enables pairing sensor devices with actuator devices without the presence of CLU.

- **Activation of DistributedLogic mode** occurs when CLU is not present in the system or in the event of a 5-second loss of communication (TF-bus) with CLU.
- **Signaling of DistributedLogic mode** in the case of pageless mode of operation and pages like Buttons and Thermostats, the 'no CLU' (crossed out CLU) sign blinks. In the case of the FreeDraw type of page text 'NO_CLU' is displayed.
- **Work in DistributedLogic mode** is only possible for configured Buttons type pages. Thermostats and FreeDraw pages are inactive, only signaling no communication with CLU. By pressing the button on the Buttons page, a message is broadcast on the TF-bus with the ID from DistributedLogicGroup_X feature. All actuator devices (e.g. Relay) receive such a package and react accordingly. A short press of the button generates a signal realizing the Switch method, while a longer one - two methods SwitchOn and SwitchOff. All 4 pages, configured as Buttons, can generate up to 16 different control signals.
- **Deactivation of DistributedLogic mode** occurs immediately in case of appearance communication (TF-bus) with CLU. In practice, it will be the reboot the whole system with the CLU connected and working properly.

14. Update process



ATTENTION!

Before proceeding with the Grenton Smart Panel module update, you must first update the firmware on the CLU Z-Wave and update the interface base. The entire upgrade procedure must

follow the following steps:

1. Please read the release note first to make sure that the new software package is compatible with your system.
2. CLU Z-Wave firmware update.
3. Updating the XML interface base.
4. Smart Panel firmware update (according to the below procedure of Smart Panel update).
5. Perform a CLU Discovery operation.

Smart Panel firmware update process:

1. Disconnect the Grenton Smart Panel from the power supply.
2. Remove the microSD card from the memory slot according to the procedure in the manual or the datasheet.
3. Upload/overwrite the file with the new version of the software and icons to the memory card.
4. Insert the memory card back into the slot.
5. Connect the power supply to the Grenton Smart Panel.
6. When the module is powered up and a newer firmware version is detected, it will start the update procedure.
7. The firmware update process is signalled by alternating blinking of the upper LEDs.
8. Correct completion of the update is confirmed by all LEDs blinking green several times.
9. If the update process fails, the whole procedure should be repeated.

In case of further unsuccessful upgrade attempts, please contact our Technical Support Department.

15. Usage and maintenance guidelines

The front of the touch panel is made of genuine leather. Occurring natural differences between the individual copies are allowed, which makes each product original. The surface of each panel can give a different optical impression, which is proof of the natural origin of the material. Production from different material fragments, different texture, shades, processing methods and coloring have an impact on the appearance of each device.

Rules of usage and maintenance:

Leather and leather products require special and skillful care. New products are treated with professional protective agents to protect against increased humidity or excessive sunlight that could lead to leather dryness. To keep leather elements in good condition, user care is essential.

- The product should not be used in sunny places and in the direct proximity of heat sources (for example: fireplaces, radiators, etc.) or exposed to direct sunlight, moisture.
- Failure to comply with the instructions may cause deformation, delamination or other material damage.
- For cleaning, aside from professional cleaning agents, you can use only a gently dampened cloth with water. It's not recommended to use chemicals not specifically intended for leather products. After cleaning out the leather must be completely dry.
- Avoid using strong chemicals for cleaning the panel, including those with vinegar and alcohol. This will remove the protective layer, causing discoloration and dry out the leather.
- For conditioning, only products designed for leather items should be used. If the item is exposed to high humidity and dirt, an appropriate solution would be leather balm or leather milk. For regular maintenance and keeping the leather in good condition, leather wax should be used.

16. Warnings and cautionary statements



ATTENTION!

- Before proceeding with the assembly, read the installation schematics and full instructions available at www.grenton.com. Failure to follow the guidelines contained in the instructions and other requirements of due care valid as a result of the nature of the equipment (device) may be dangerous to life / health, damage the device or installation to which it is connected, damage

other property or violate other applicable regulations. The manufacturer of the device, Grenton Sp. z o.o. does not bear any responsibility for the damage (property and non-property related) resulting from the assembly and / or use of the equipment not in accordance with the instructions and / or due diligence in handling the equipment (device).

- Device power supply, permissible load or other characteristic parameters have to be in accordance with the device specification, described in particular in the "Technical data" section.
- The product is not intended for children and animals.
- If you have technical questions or comments about the device operation, contact Grenton Technical Support.
- Answers to frequently asked questions can be found at: www.support.grenton.pl



DANGER!

- Danger to life caused by electric current!
- The components of the installation (individual devices) are designed to work in a home electrical installation or directly in its

vicinity. Incorrect connection or use may cause a fire or electric shock.

- All work related to the installation of the device, in particular works involving interference in the electrical installation, may be performed only by a person with appropriate qualifications or licences.
- When installing the device, make sure that the power supply voltage is disconnected from the circuit in which the device is connected or near which the assembly takes place.

17. CE marking

The manufacturer declares that the device is in full compliance with the requirements of EU legislation that includes the directives of a new approach appropriate for this equipment. In particular, Grenton Sp. z o.o. declares that the device fulfills the requirements on safety, specified by law, and that it conforms to

the national regulations that implement the appropriate directives: The Directive on the electromagnetic compatibility (EMC - 2014/30/UE) and the Directive on the limitation of the use of specific substances in electrical and electronic equipment (RoHS II - 2011/65/UE).



18. Warranty

Warranty available at: www.grenton.com/warranty

19. Manufacturer contact details

Grenton Sp. z o.o.
ul. Na Wierzchowinach 3
30-222 Kraków, Polska (PL)
www.grenton.com